

**INSTRUCTIONS**  
**FOR ASSEMBLY AND USE OF MB-86 Fold Line ALUMINIUM**  
**FOLDING DOOR**

## 1. DESCRIPTION OF THE CONSTRUCTION

The MB-86 Fold Line system of folding door with thermal partition is used to make elements of architectural external fitting, opened outwards and inwards, characterised by high thermal and acoustic insulation as well as water and air tightness. This system meets all the requirements relating to energy saving and environmental protection. The parameters of the door made of MB-86 Fold Line system elements exceed the requirements of the most stringent applicable regulations and standards.

### MB-86 Fold Line DOOR SYSTEM FEATURES:

- The constructional depth of sections is: 86 mm (frame), 77 mm (leaf), 77, 86, 137 mm (threshold). The depths of sections assumed in such a way give the effect of a single plane after closing between the frame and the leaf only on one side, however, the leaves between each other are flush on both sides.
- The profiles used in the system have a three-chamber construction where the central chamber is the insulation chamber between shaped thermal breaks with a width of 34 or 24 mm.
- The heat transfer coefficients (Uf) for folding door frames achieve excellent values locating this system among clear market leaders in this category.
- The high water penetration and air infiltration tightness as well as the excellent thermal insulation can be achieved, inter alia, due to the special shapes of cover gaskets and glass gaskets.
- The closed-shape glass strips ensure strong filling attachment which in turn significantly facilitates achievement of anti-burglary constructions.
- The internal glass gaskets are deeply set in the glass strips therefore they are hardly visible from the inside.
- The ranges of glass thicknesses possible for glazing: from **13.5 to 61.5 mm**. Due to a wide range of glazing all the types of acoustic or anti-burglary two-chamber glass packages available on the market can be installed.
- Maximum and minimum dimensions of folding door **leaves**:  
Maximum height =2.7 m  
Minimum width =0.7m  
Maximum width =1 m  
Maximum leaf weight - 100 kg
- The MB-86 Fold Line system is compatible with other aluminium systems produced by Amberline, in particular, with MB-86.
- The MB-86 Fold Line system door can be manufactured with a low threshold, which is especially recommended to the rooms for older people or people with disabilities.

### CONSTRUCTION OF THE PROFILES

The profiles used in the MB-86 Fold Line system have a three-chamber construction where the central chamber is the insulation chamber between thermal breaks with a width of 24 and 34 mm. The system of joints by means of thermal breaks allows for the use of two-colour profiles – different inside and outside the construction. The chamber shape of thermal breaks guarantees high rigidity, very good thermal insulation and proper drainage from internal chambers of the profile.

### THERMAL BREAKS AND PARTITIONS

The thermal breaks and partitions are formed as sections made of polyamide reinforced with glass fibre PA 6,6 GF25 according to DIN 16941 T.2 (they are certified by the manufacturer). The chamber thermal breaks are characterised by very high durability and thermal expansion similar to aluminium

A M B E **R** L I N E

Amberline Sp. z o.o.  
78-100 Kołobrzeg, ul. K. Kolumba 20  
[www.amberline.eu](http://www.amberline.eu)

which excludes deformation of the joint and prevents break of joints between polyamide and aluminium in case of high temperature variations on the elevation of the buildings.

### MARKING OF DOOR TYPES

Figure 1 presents the view of the construction on the **external** side, i.e. on the side on which the glass strips are not visible.

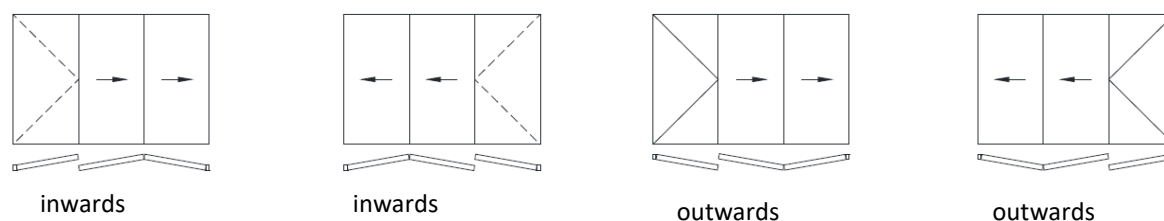

Fig. 1. Marking of door types.

The door can be manufactured in various configurations, marked with ciphers. The first cipher means the total number of leaves in the set, the second cipher: the number of leaves folded to the left side (when viewed from the outside) and the third cipher: the number of leaves folded to the right side.

The configurations: 3-3-0; 3-0-3; 3-2-1; 3-1-2; 5-5-0; 5-4-1; 5-3-2; 5-2-3 are manufactured with an active leaf, i.e. they have a door lock and when opening this leaf, we follow the description relating to a "single-leaf door", except that the opening angle is almost 180°, which means that it can be opened onto the adjacent leaf.

The configurations: 4-3-1; 4-1-3; 6-5-1; 6-1-5; 6-3-3 are manufactured with an active and passive leaf. When opening this leaf, we follow the instruction relating to a "two-leaf door".

The other leaves of a given construction are opened as follows: if a door handle is equipped with an insert, first it should be unlocked with a key, then the door handle must be turned by 90° (as shown in Figure 2) to set it in a horizontal position in relation to the threshold. In the next step, the door handle should be pulled inside if the door opens inwards or pushed if the door opens outwards. This will bring the adjacent leaves nearer to each other. The order of opening of individual leaves is shown in Figure 2.

The door is closed in the order reverse to the one described above.

A M B E R L I N E

Amberline Sp. z o.o.

78-100 Kołobrzeg, ul. K. Kolumba 20

[www.amberline.eu](http://www.amberline.eu)

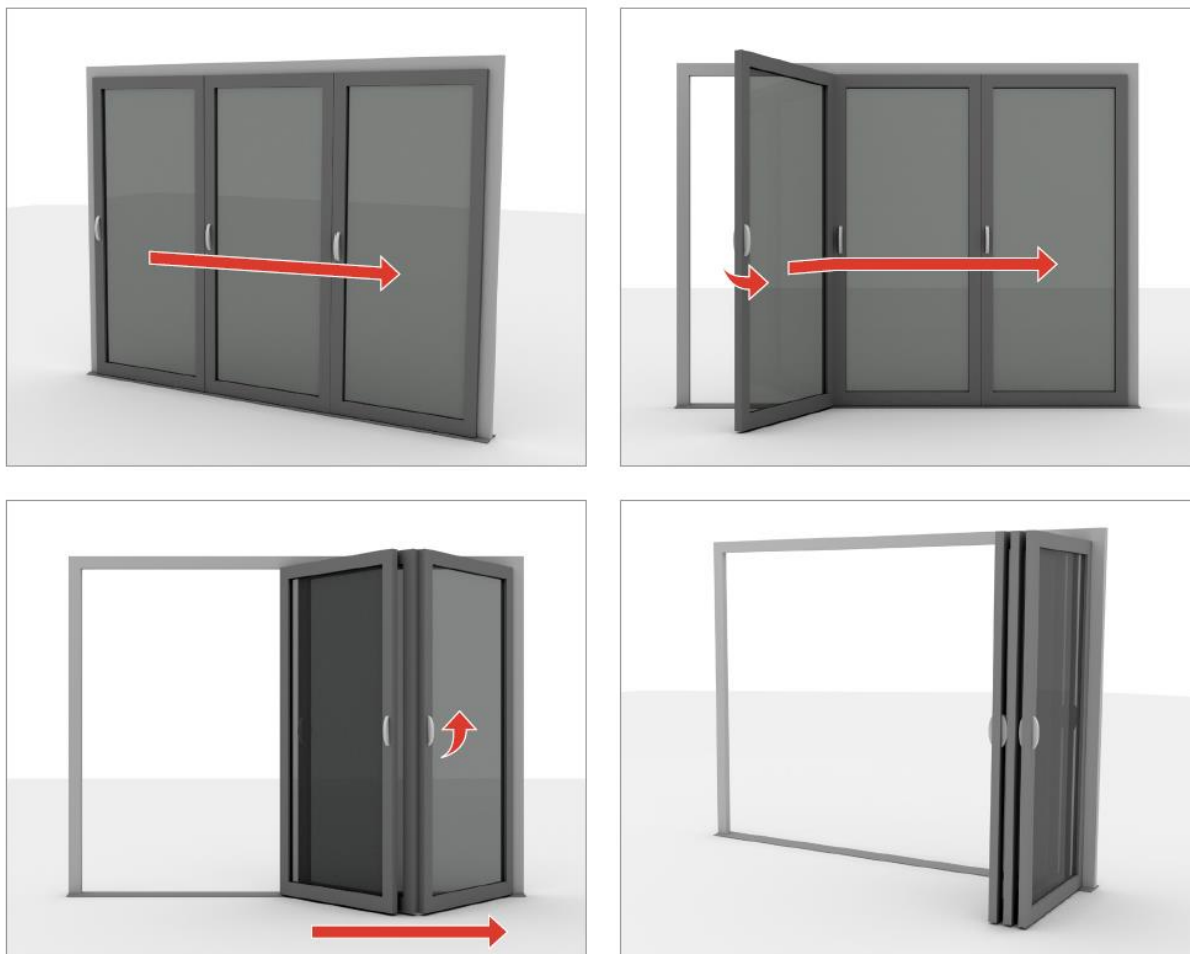

Fig. 2. Opening of folding door.

### ACOUSTIC INSULATION

The acoustic insulation indices  $R_w$  (C, Ctr), RA1 and RA2 depend on the used glass package and construction type.

### AIR PERMEABILITY

The air permeability of external fitting door was classified according to PN-EN 12207, min. in the class 3.

### THERMAL INSULATION

The heat transfer coefficients ( $U_f$ ) of MB-86 Fold Line system door frames were calculated according to the guidelines of PN-EN ISO 10077-2.

## 2. GUIDELINES FOR ASSEMBLY ON SITE

The modern MB-86 Fold Line system windows and doors retain their very good operating properties on the condition that they are properly installed to the walls of the building. The design of the connection of the door with the building is the designer's responsibility and depends on individual construction solutions. This connection is to ensure tightness, thermal insulation and proper load transfer onto the load bearing construction. The following operations have impact on the proper assembly of the product:

- PREPARATION OF AN OPENING IN THE WALL OF THE BUILDING

A M B E R L I N E

Amberline Sp. z o.o.  
78-100 Kołobrzeg, ul. K. Kolumba 20  
[www.amberline.eu](http://www.amberline.eu)

The opening in the wall in which a window or door is to be installed should have dimensions respectively larger than the external frame dimensions. The size of gaps between the aluminium frame and the wall depends on the length of sections, their colour and the way in which the gaps are filled. The angles of the opening should have 90° and the diagonals should not differ by more than 1 cm which can be easily checked by means of a tape or a string. If the corners do not keep the right angle, the frame geometry can be deformed which affects the functionality of the entire product. All the internal surfaces of the opening should be possibly smooth and without defects. **The bottom surface of the opening should be horizontal, uniform, even, made of a material on which the product can be stably based.**

- **SETTING OF THE FRAME IN THE WALL**

The door is set on a load-bearing threshold which ensures continuous load transfer, thermal insulation and maintenance of level (**the maximum inclination is 0.5 mm/1 m of threshold length**). The position of the window or door relative to the wall should be such that the 10°C isotherm passes through this construction. Only then, a phenomenon of water vapour condensation on the internal side of the product under normal use conditions can be avoided. In a sandwich wall insulated with mineral wool or foamed polystyrene, this isotherm is located within the belt of insulating material therefore the installation should be carried out to its depth. If the wall is insulated from the outside, it is recommended to install the aluminium construction near the belt of the external insulation. The gap between the frame and the wall on both sides should be equal and must ensure free compensation of thermal dilatation of the product.

- **FASTENING OF THE PRODUCT IN THE WALL**

The door must be set mechanically. Foams, glues and similar are not accepted as a fastening element.

It is recommended to fasten the door by means of steel anchors or bolts and screws made of stainless or galvanised steel and with use of supporting blocks. The fastening must guarantee the transfer of external loads onto the building construction and at same time the functionality of the door must be maintained (the movement of leaves while closing or opening should be smooth). On each side of the construction it is necessary to use at least 2 fastening points in spans not exceeding 800mm in case of dowels, 400mm in case of anchors (Figure – page 6). When selecting lots and screws their manufacturer's recommendations included in its catalogue should be taken into account.

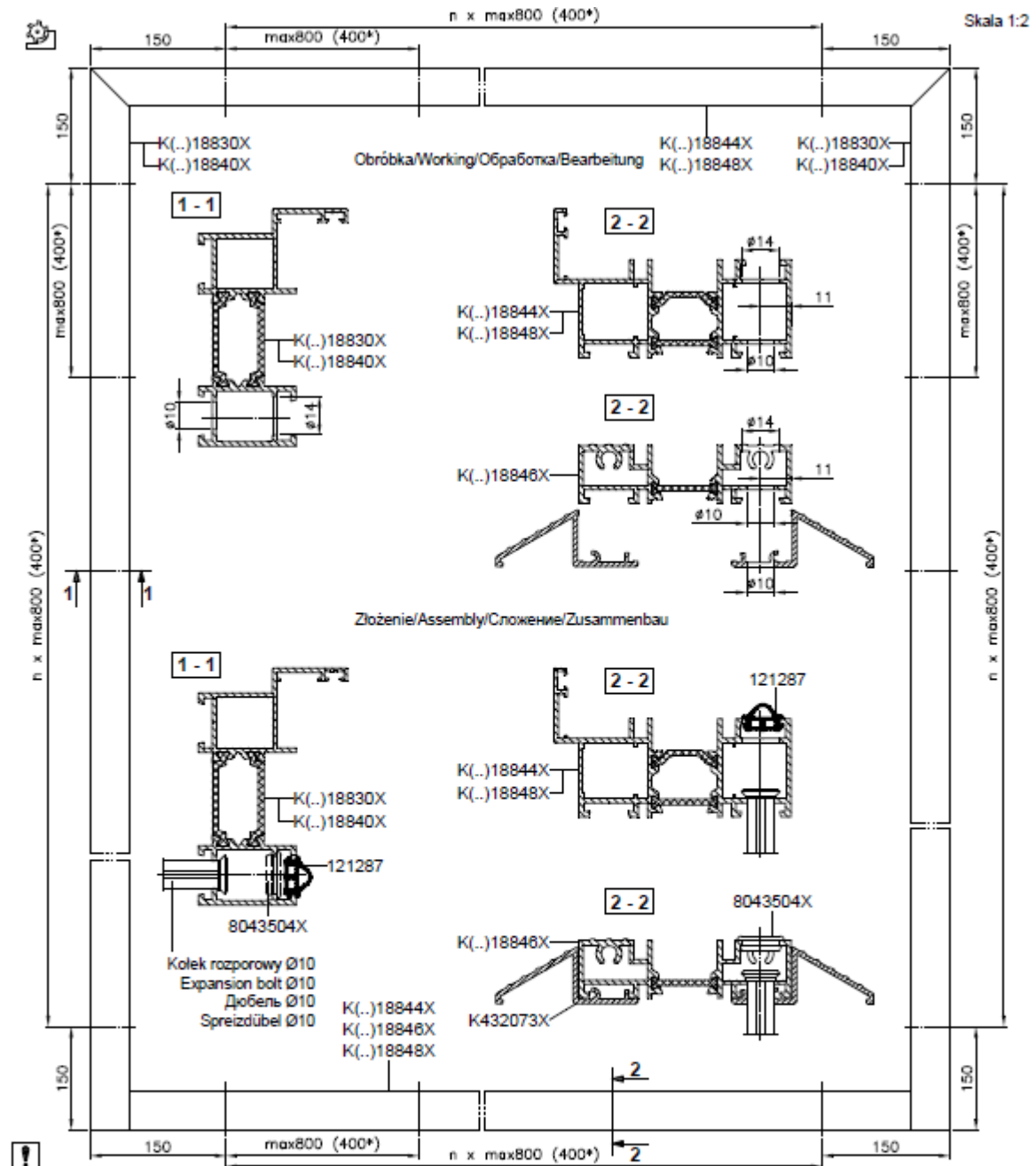

Otwory w ościeżnicach K(..)18830X, K(..)18840X, K(..)18844X, K(..)18846X, K(..)18848X, wierceń od przyrządu P9K-859-00. (400\*) - w przypadku montażu ościeżnic za pomocą kotew 80311040. Otwory pod kołki należy przesunąć o 150 mm od osi przewiązek, oraz max 100 mm od osi zawiasów drzwi.

Drill holes in frames K(..)18830X, K(..)18840X, K(..)18844X, K(..)18846X, K(..)18848X, using a device P9K-859-00. (400\*) - if frames are fastened with anchors 80311040. Move holes to hold expansion bolts by 150 mm from axis of lacing, and max 100 mm from the axis door hinges.

Отверстия в створках K(..)18830X, K(..)18840X, K(..)18844X, K(..)18846X, K(..)18848X, сверлить со стороны приспособления P9K-859-00. (400\*) - в случае монтажа коробок с помощью анкеров 80311040. Отверстия под дюбели следует переместить на 150 мм от оси импостов, а также не более чем на 100 мм от оси дверных петель.

Die Bohrungen in Blendrahmen K(..)18830X, K(..)18840X, K(..)18844X, K(..)18846X, K(..)18848X, sind mit der Bohrvorrichtung P9K-859-00 herzustellen. (400\*) - wenn die Blendrahmen mit den Ankern 80311040 befestigt werden. Die Bohrungen für Spreizdübel sind um 150 mm gegenüber der Kämpferachse und max. 100 mm gegenüber der Türachse zu verschieben.

It is necessary to check if the drainage holes in the windows are not contaminated or blocked. If need be, the holes should be thoroughly cleaned and cleared.

**A M B E R L I N E**

Amberline Sp. z o.o.

78-100 Kołobrzeg, ul. K. Kolumba 20

[www.amberline.eu](http://www.amberline.eu)

## • GLAZING

When glazing is installed in the door leaf, it is absolutely necessary to ensure the even support of the entire thickness of the pane, no contact of the pane with the frame by the use of intermediate blocks and proper room between the frame and the pane. The blocks should be placed in the leaf according to the below diagram.

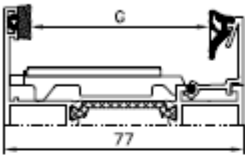
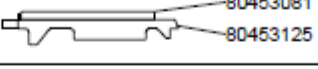
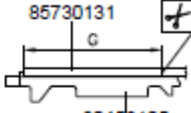
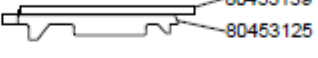
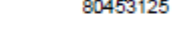
Skala 1:2		Podkładka nosna Main washer Несущая подкладка Glasauflage	Podkładka dystansowa Distance washer Регулировочная подкладка Distanzunterlage
	$13,5 \leq G < 45$		
	$45 \leq G \leq 61,5$		

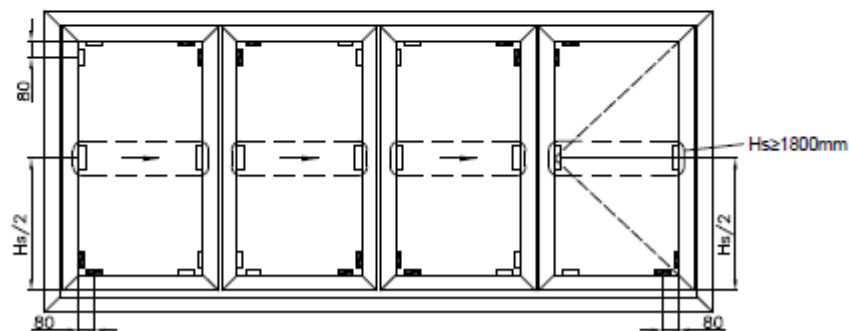

## • ADJUSTMENT OF THE FITTINGS

It is unacceptable to contaminate the fittings by sand, plaster or other foreign bodies. When the leaves are installed, their position in relation to the frame and adjacent leaves should be corrected by adjustment of the fittings cooperating with each other (hooks, pins). The leaves should be levelled and the distances between the profiles of adjacent leaves – equal.

So called fitting countering (locking) is very important because it sets the fittings in a proper position and prevents the (earlier set) leaves from moving. For this purpose, it is necessary to screw in a counter (lock) screw shown in the figure below – **marked as A**.

A M B E R L I N E

Amberline Sp. z o.o.  
78-100 Kołobrzeg, ul. K. Kolumba 20  
[www.amberline.eu](http://www.amberline.eu)





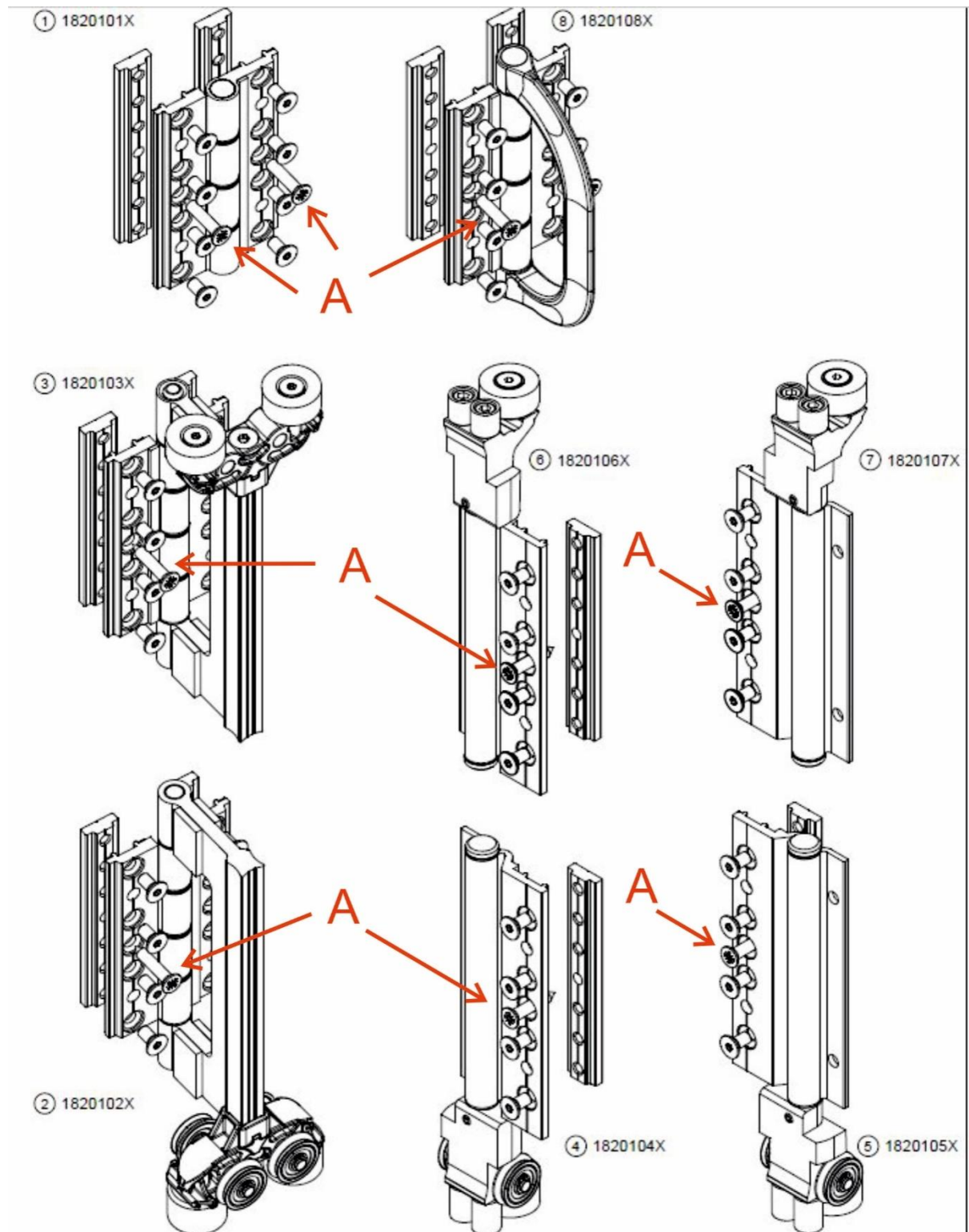

#### • PERFORMANCE OF THE PRODUCT INSULATION

The objective of the insulation of the space between the frame and the wall is to protect from water penetration, both rainfall water – on the external side, and water vapour – on the internal side; furthermore, its task is to ensure thermal and acoustic insulation. Mineral wool, montage foams or polyethylene rolls, silicone masses, expansion tapes as well as steam and steam-tight foils are typically used for this purpose. The insulation layer around the frame should be uniform,

**A M B E R L I N E**

Amberline Sp. z o.o.  
78-100 Kołobrzeg, ul. K. Kolumba 20  
[www.amberline.eu](http://www.amberline.eu)

without breaks and of equal thickness. The steam permeable insulation is made on the external side, particularly carefully along the bottom frame and corners. It should be remembered to ensure very good vapour penetration insulation on the internal side of the montage gap. If the window opening recesses are plastered after the installation of the aluminium construction the door should be protected that the plaster does not come into contact with the surface of the product.

After the protective foil of the profiles on the external side is removed (the protective foil cannot be removed later), the gap between the frame and the wall should be filled with thermally insulating material, e.g. special expanding steam permeable tape – on the external side; polyurethane foam, sealing cords – on the internal side. When the polyurethane foam is used, attention should be paid to the fact that on cold days the foam temperature is similar to the temperature in the room (minimum 5°C), or the foam manufacturer's instructions should be strictly followed. When the foam is set, its excess must be removed by cutting with a sharp knife (the foam must not be scraped or picked out – its surface after cutting should be smooth and protected against wetting – it is best when the surface forms so called intact skin); finally, the joint should be plastered.

**NOTE:**

**Lime, cement, alkaline and cleaning materials (e.g. bleaches, abrasive pastes) have a particularly negative effect on aluminium sections, especially, on decorative protective surfaces. Therefore, the finishing "wet" works should be limited to the minimum. If the mortar comes into contact with the surface of aluminium, the mortar should be immediately washed out (the mortar cannot harden). The failure to wash out will result in permanent surface discoloration and damage. At places when the aluminium surface comes into contact with other metals or other alloys, electrochemical aluminium oxidation occurs. This corrosion develops particularly fast under conditions of increased humidity. Aluminium therefore should be always separated from other metals with an insulating layer.**

**NOTE: THE PROTECTIVE FOIL ON THE PROFILES MUST BE REMOVED IMMEDIATELY AFTER THE INSTALLATION OF THE WINDOWS BUT NOT LATER THAN 3 MONTHS AFTER THE DATE OF THE DELIVERY OF JOINERY, REGARDLESS OF THE PERFORMED INSTALLATION WORKS. THE PROFILES SHOULD BE PROTECTED AGAINST DAMAGE CAUSED BY FURTHER CONSTRUCTION AND REPAIR WORKS.**

**NOTE: ALL THE ELECTRICAL WORKS LINKED WITH THE CONNECTION OF CONTROL ELEMENTS OF THE CONSTRUCTION MUST BE PERFORMED BEFORE THE START OF PLASTERING WORKS. THE ELECTRICAL CONNECTIONS MUST BE CARRIED OUT BY A PERSON WITH PROPER ELECTRICAL QUALIFICATIONS FOR ABOVE-MENTIONED WORKS.**

### **3. MAINTENANCE**

The regular and proper maintenance will ensure the door's long-term functional and aesthetic properties being preserved. The following maintenance operations should be performed at least once a year:

- check the functioning of the fittings and leaves, in particular, inspect all screws and fastening stability of door handle, clean and preserve the fittings;
- check the adhesion of the leaf gasket to the frame, preserve the gasket;
- check the drainage gaps – clean the holes and supplement the covers of drainage holes. The clearance of the drainage holes should be controlled, and cleared, if necessary. All contaminations, sand, foreign bodies should be removed by a vacuum cleaner;

**A M B E R L I N E**

Amberline Sp. z o.o.  
78-100 Kołobrzeg, ul. K. Kolumba 20  
[www.amberline.eu](http://www.amberline.eu)

- maintain the bottom guide rail – all contaminations such as dirt, sand, gravel, foreign bodies should be removed by a vacuum cleaner (this operation must be carried out at least once a month);

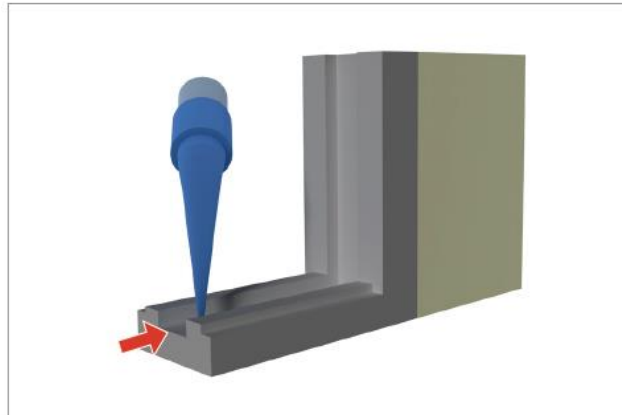

- construction/aluminium profiles should be washed with the use of pH neutral diluted liquid or clean water at least twice a year. Aluminium anodised or painted sections should be washed with a soft cloth and gentle cleaning agents. Liquids based on highly alkaline or acidic solutions must not be used as they can cause damage to oxide films or painted coats. It is forbidden to use cleaning agents with pH below 5 or above 8. When washing the coat, its temperature and the water temperature cannot exceed 25°C. The surface must be immediately rinsed with clean water after each washing. Regular washing prevents formation of intensive difficult-to-remove stains. It is forbidden to use ice-melting salt or chemical agents near the profiles. It is forbidden to use detergents of unknown origin. It is forbidden to use organic solvents containing esters, ketones, alcohols, aromatic compounds, esters of glycols, chlorinated hydrocarbons etc.;
- cylinder insert should be maintained only with the use of graphite powder;
- all moving fitting elements should be lubricated with machine oil or grease free from resins and acids, available in specialised commercial outfits or shops. The instructions supplied by the grease/machine oil manufacturers should be followed. Steel hooks must be lubricated with machine oil. Greases should be applied into each fitting hole. After lubrication, a leaf should be opened/tilted until grease is distributed. Excess grease must be removed.

## MAINTENANCE OF GASKETS

The gaskets play an important role against water and wind penetration. They must be therefore washed as the aluminium profiles. After each washing, they should be wetted and preserved with silicone grease or acid-free technical petroleum jelly. The gaskets cannot be cleaned with the use of aggressive chemical agents and solvents.

**A M B E R L I N E**

Amberline Sp. z o.o.

78-100 Kołobrzeg, ul. K. Kolumba 20

[www.amberline.eu](http://www.amberline.eu)

#### 4. EXAMPLES OF FOLDING DOOR ASSEMBLY

##### Bottom setting of the door

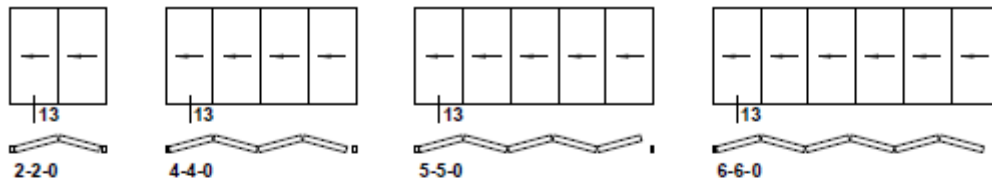

13

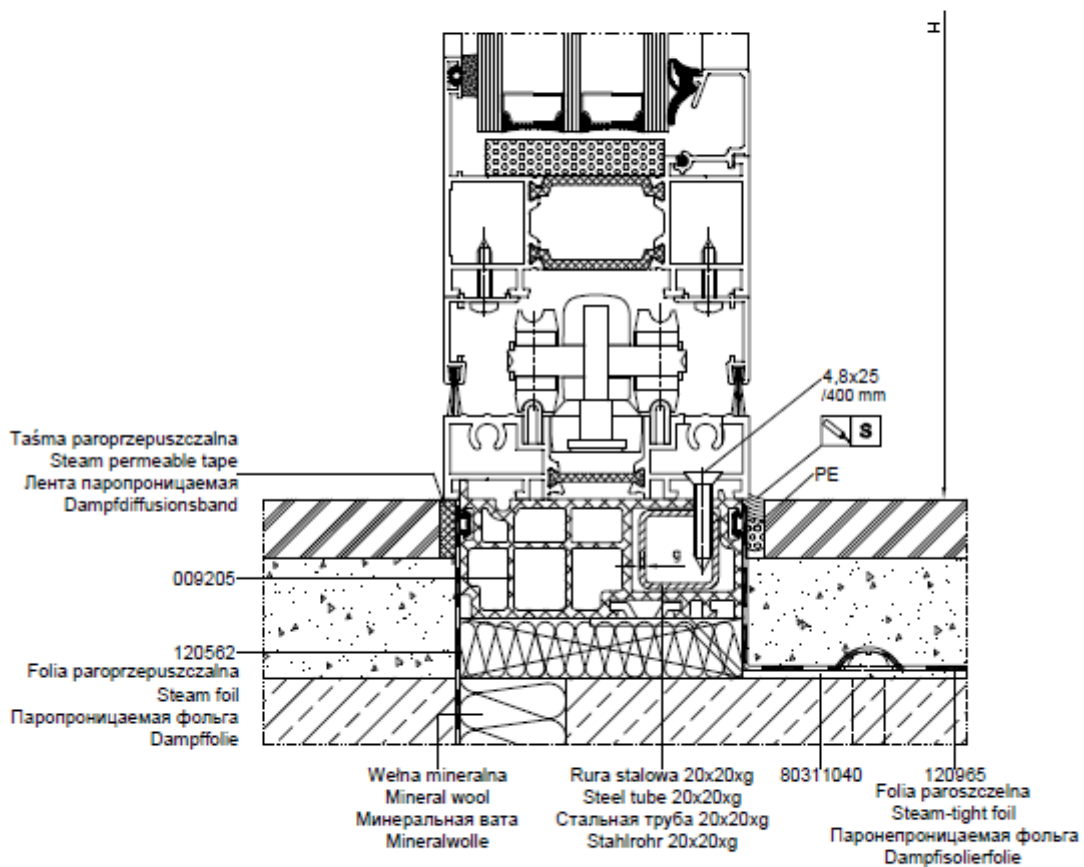



 Przykład dolnego osadzenia drzwi w murze warstwowym.  
 An example of bottom setting of a door in a sandwich wall.  
 Пример нижней установки окна в многослойной стене.  
 Beispiel des unteren Türanschlagens in einer Schichtenmauer.

**A M B E R L I N E**

Amberline Sp. z o.o.  
 78-100 Kołobrzeg, ul. K. Kolumba 20  
[www.amberline.eu](http://www.amberline.eu)

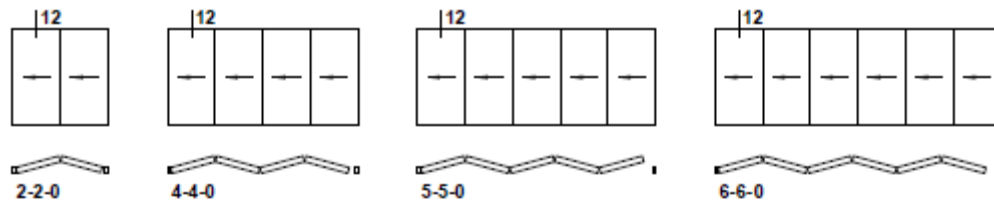
## Upper setting of the door



12

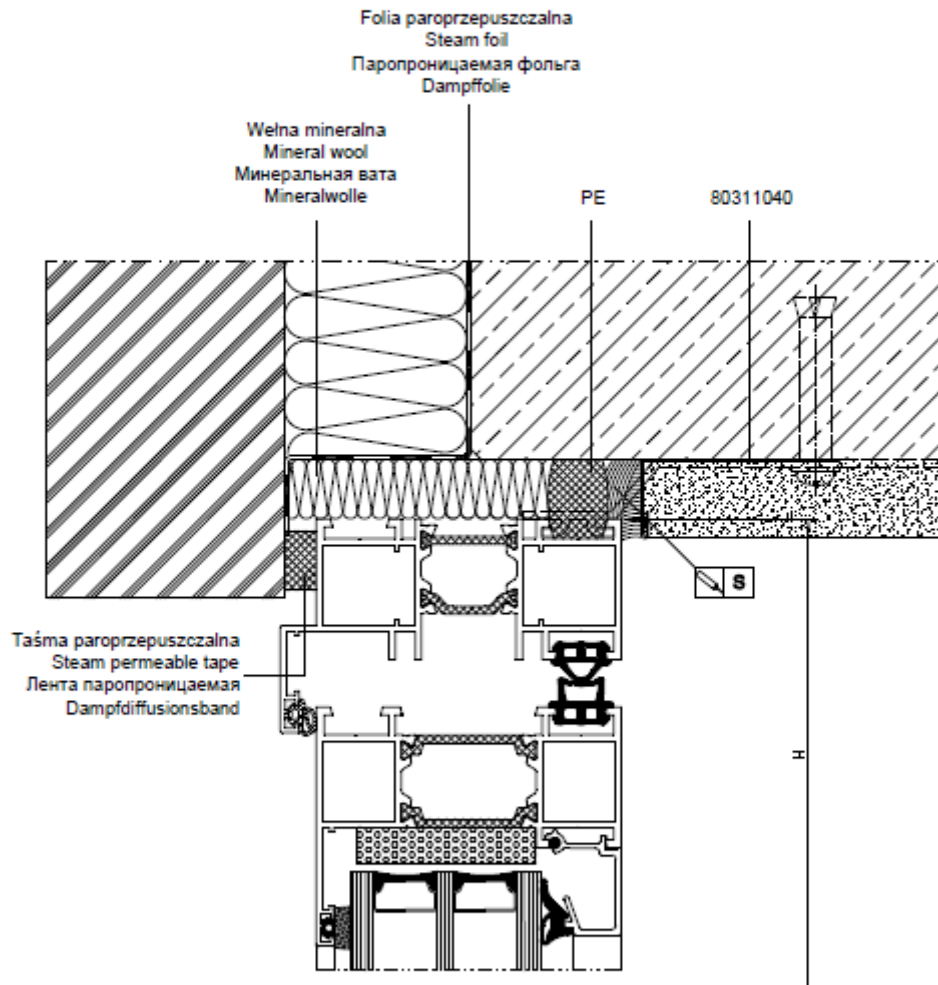

**I** Przykład górnego osadzenia okna otwieranego w murze warstwowym. Analogicznie osadzić okno stałe.  
 An example of upper setting of an opening window in a sandwich wall. Similarly assemble a fixed window.  
 Пример верхней застройки открываемого окна в многослойной стене. Глухое окно установить аналогично.  
 Beispiel des oberen Anschlagens von öffnendem Fenster in einer Schichtenmauer. Das Festfenster analog anschlagern.

**A M B E R L I N E**

Amberline Sp. z o.o.  
 78-100 Kołobrzeg, ul. K. Kolumba 20  
[www.amberline.eu](http://www.amberline.eu)

## Upper setting of the door

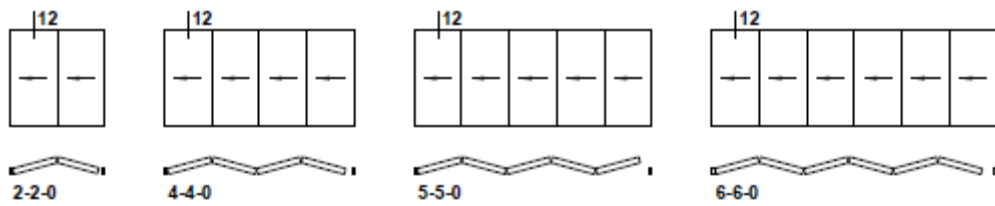

12

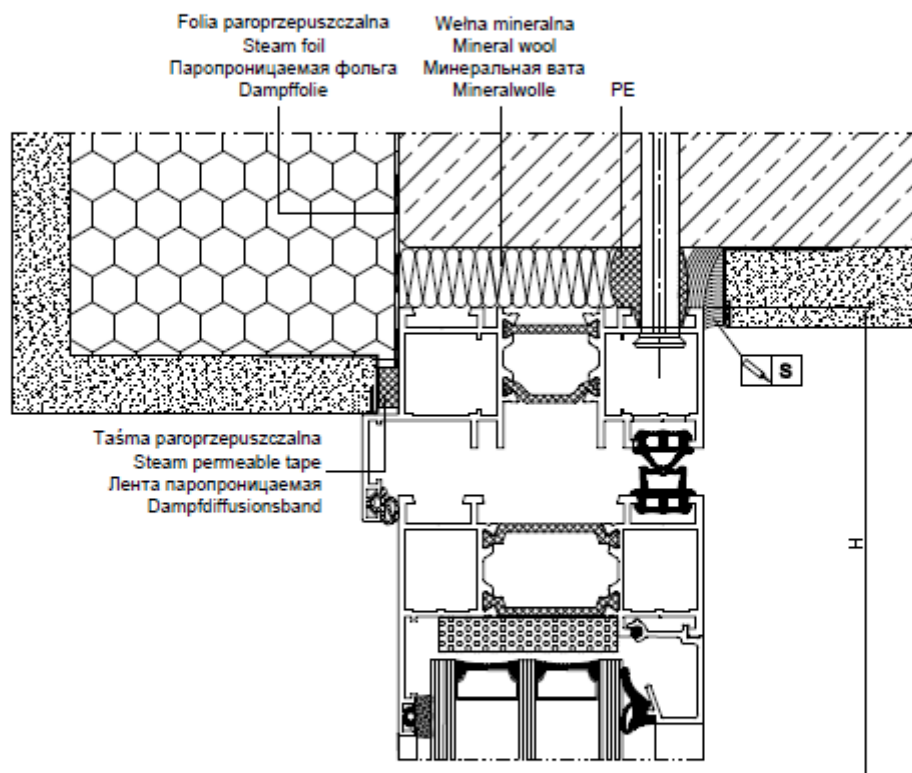

- i** Przykład górnego osadzenia okna otwieranego w murze monolitycznym docieplonym z zewnątrz. Analogicznie osadzić okno stałe.  
 An example of upper setting of an active window in a monolithic wall insulated from the outside. Similarly assemble a fixed window.  
 Пример верхней установки окна открывающегося в монолитной стене, утепленной с внешней стороны.  
 Глухое окно установить аналогично.  
 Beispiel des oberen Anschlagens vom öffnenden Fenster in einer von außen gedämmten Monolithmauer. Das Festfenster analog anschlagen.

**A M B E R L I N E**

Amberline Sp. z o.o.

78-100 Kołobrzeg, ul. K. Kolumba 20

[www.amberline.eu](http://www.amberline.eu)



## Lateral setting of the door

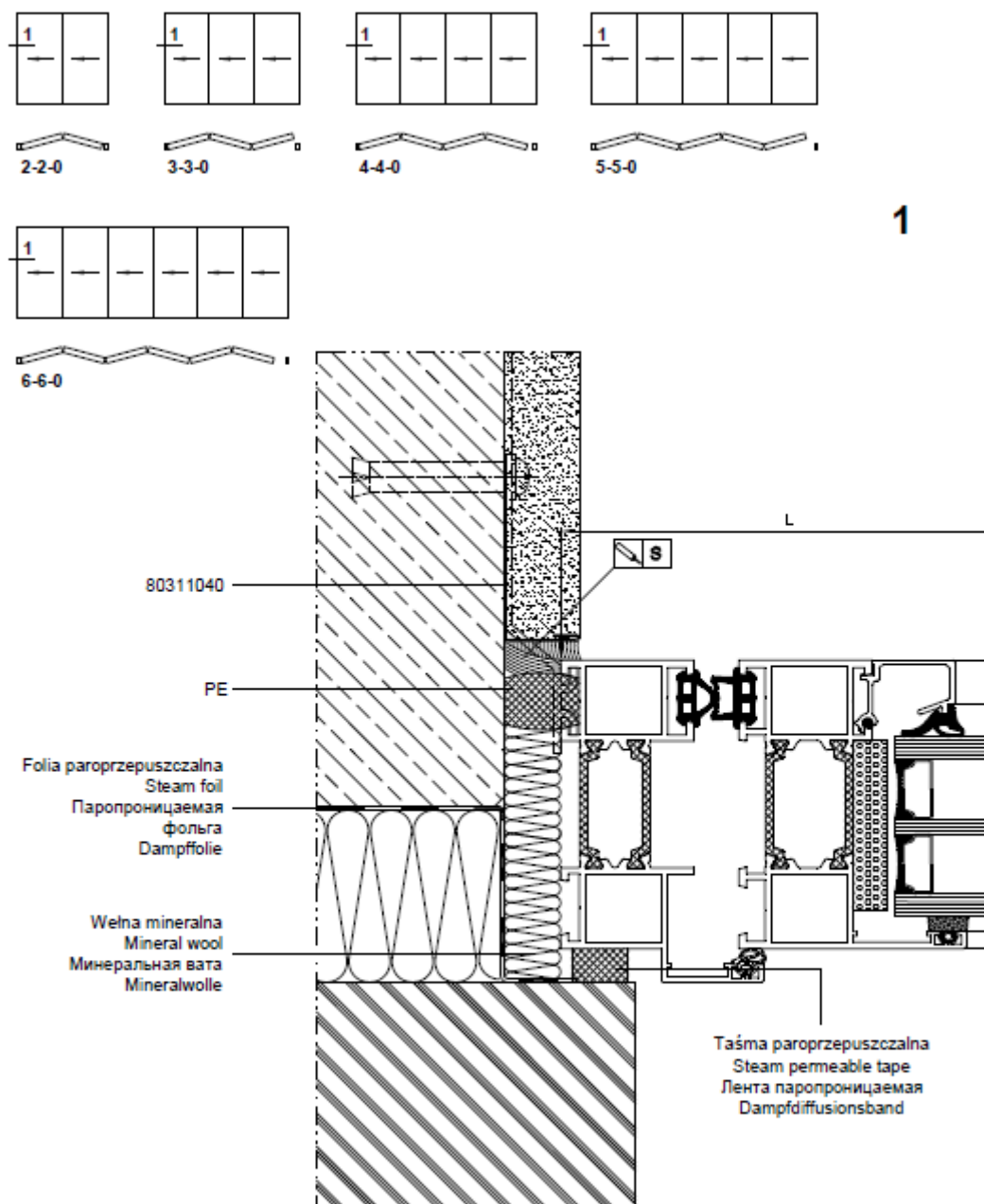

Przykład bocznej osadzenia okna otwieranego w murze warstwowym. Analogicznie osadzić okno stałe.  
An example of lateral setting of an opening window in a sandwich wall. Similarly assemble a fixed window.  
Пример боковой установки окна открывающегося в многослойной стене. Глухое окно установить аналогично.  
Beispiel des seitlichen Anschlagens vom öffnenden Fenster in einer Schichtenmauer.

**A M B E R L I N E**

Amberline Sp. z o.o.  
78-100 Kołobrzeg, ul. K. Kolumba 20  
[www.amberline.eu](http://www.amberline.eu)

## Lateral setting of the door

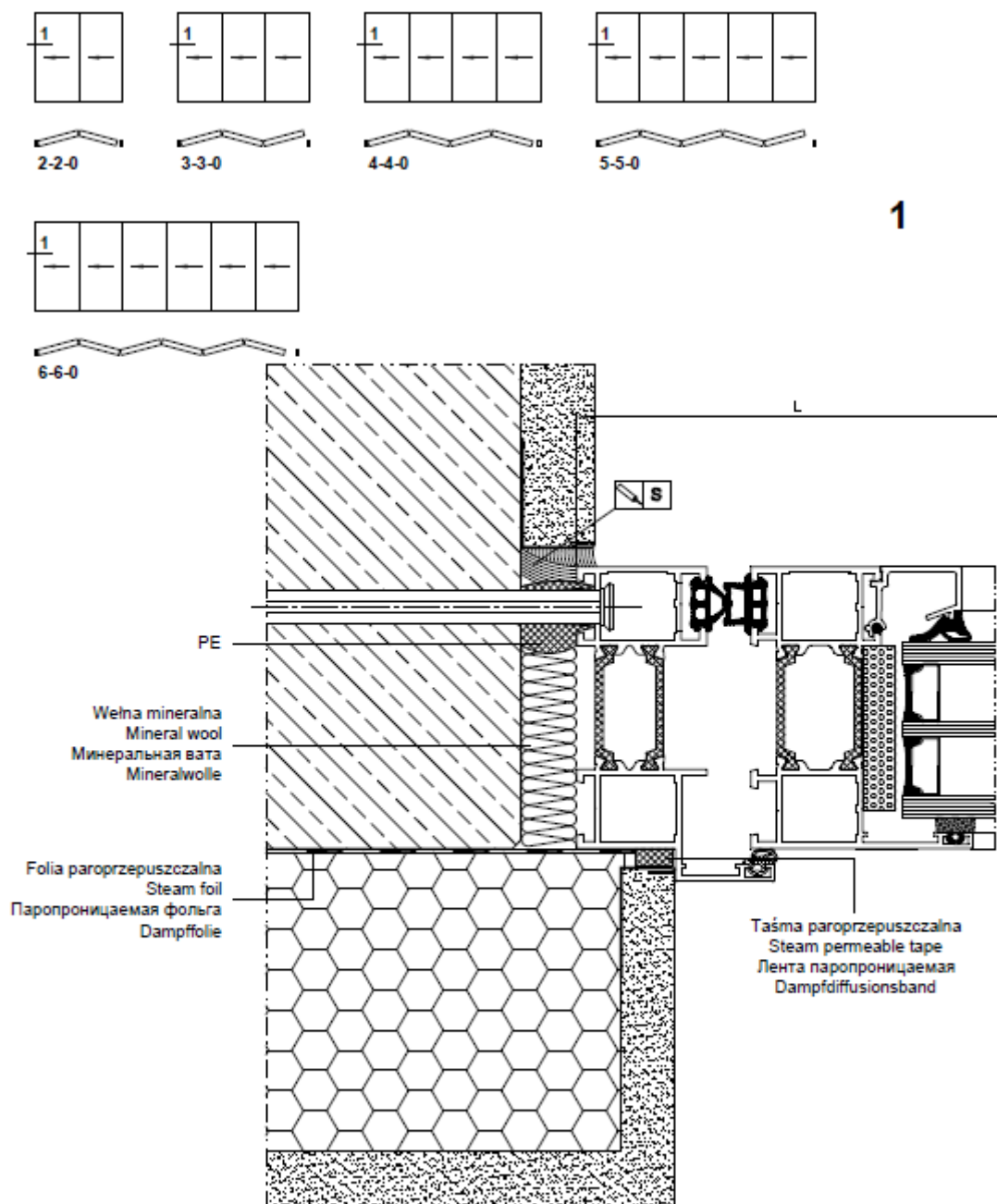

- i** Przykład bocznej osadzenia okna otwieranego w murze monolitycznym docieplonym z zewnątrz. Analogicznie osadzić okno stałe.  
 An example of lateral setting of an active window in a monolithic wall insulated from the outside. Similarly assemble a fixed window.  
 Пример боковой установки окна открывающегося в монолитной стене, утепленной с внешней стороны.  
 Глухое окно установить аналогично.  
 Beispiel des seitlichen Anschlagens vom öffnenden Fenster in einer von außen gedämmten Monolithmauer. Das Festfenster analog anschlagen.

**A M B E R L I N E**

Amberline Sp. z o.o.  
 78-100 Kołobrzeg, ul. K. Kolumba 20  
[www.amberline.eu](http://www.amberline.eu)



## Bottom setting of the door

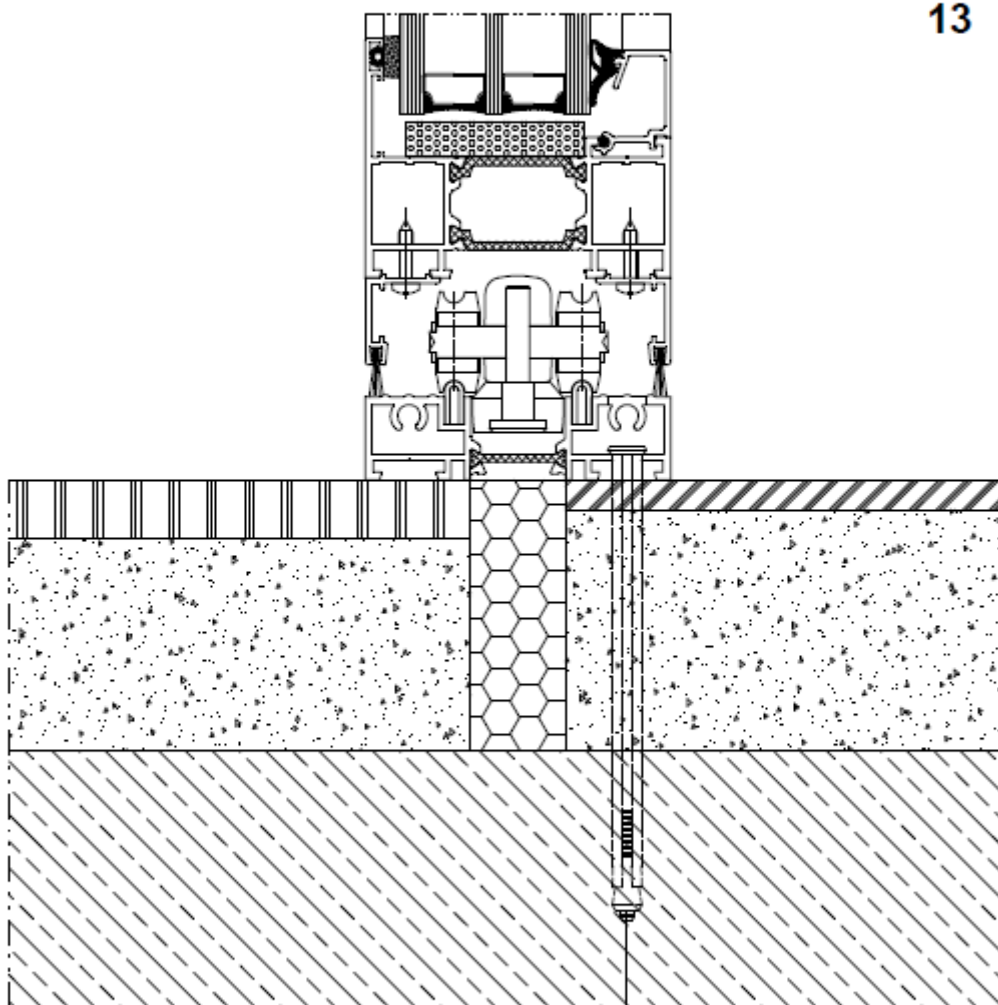
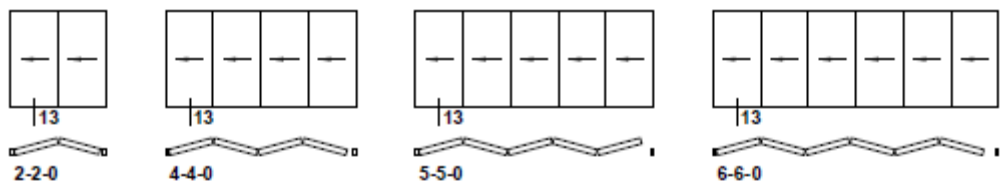

Kolek rozporowy Ø10  
Expansion bolt Ø10  
Дюбель Ø10  
Spreizdübel Ø10

**I** Przykład dolnego osadzenia drzwi w murze warstwowym.  
An example of bottom setting of a door in a sandwich wall.  
Пример нижней установки окна в многослойной стене.  
Beispiel des unteren Türanschlagens in einer Schichtenmauer.

**A M B E R L I N E**

Amberline Sp. z o.o.  
78-100 Kołobrzeg, ul. K. Kolumba 20  
[www.amberline.eu](http://www.amberline.eu)

## Bottom setting of the door

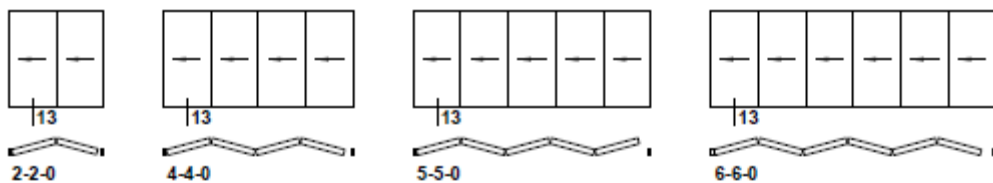

13

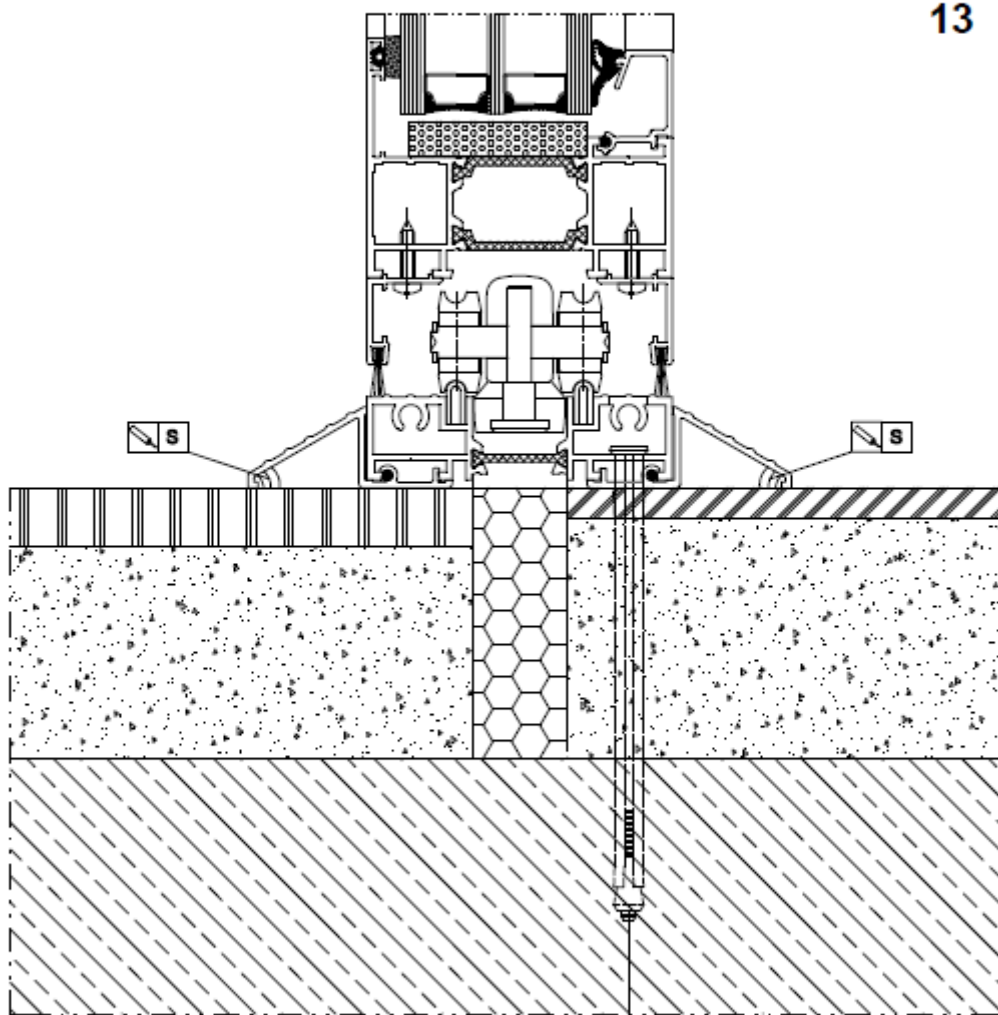

Kolek rozporowy  $\varnothing 10$   
 Expansion bolt  $\varnothing 10$   
 Дюбель  $\varnothing 10$   
 Spreizdübel  $\varnothing 10$

 Przykład dolnego osadzenia drzwi w murze warstwowym.  
 An example of bottom setting of a door in a sandwich wall.  
 Пример нижней установки окна в многослойной стене.  
 Beispiel des unteren Türanschlagens in einer Schichtenmauer.

**A M B E R L I N E**

Amberline Sp. z o.o.

78-100 Kołobrzeg, ul. K. Kolumba 20

[www.amberline.eu](http://www.amberline.eu)

## Bottom setting of the door

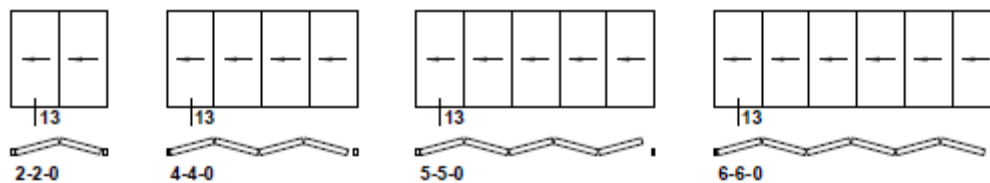

13

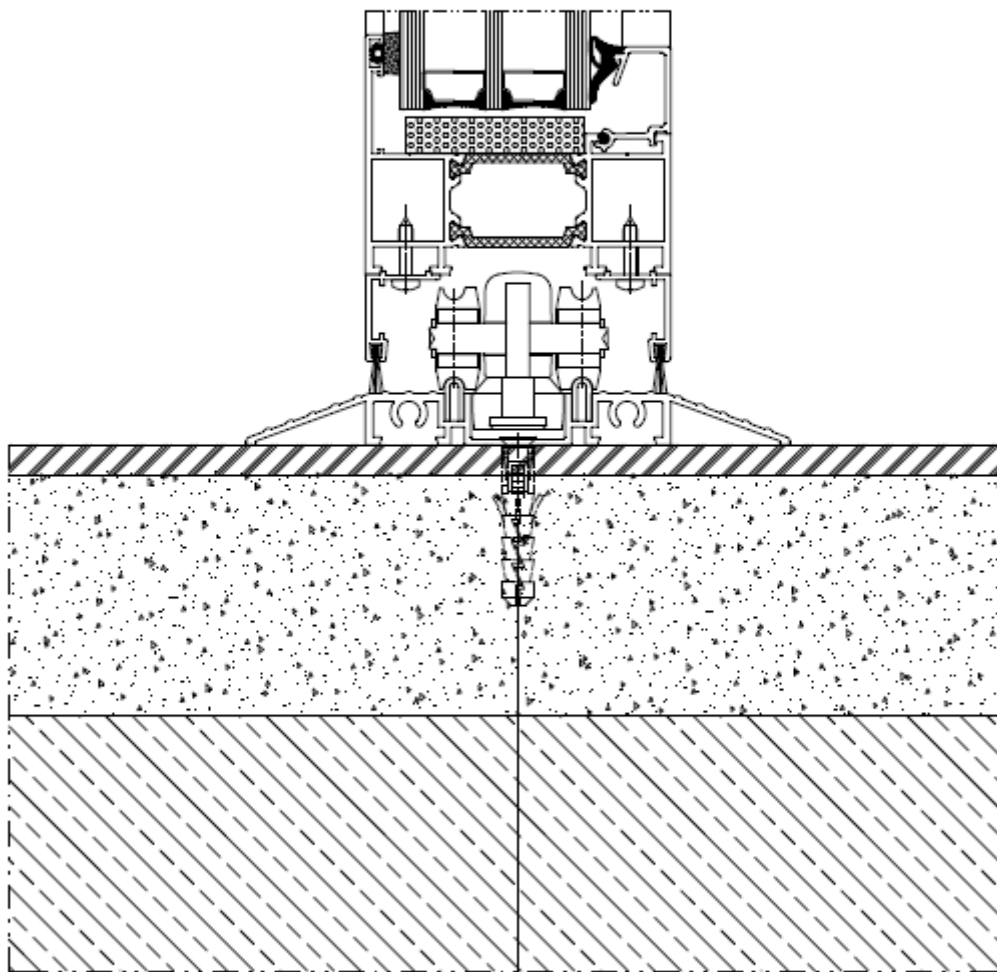

Kolek rozporowy  $\varnothing 10$   
 Expansion bolt  $\varnothing 10$   
 Дюбель  $\varnothing 10$   
 Spreizdübel  $\varnothing 10$

**I** Przykład dolnego osadzenia drzwi w murze warstwowym.  
 An example of bottom setting of a door in a sandwich wall.  
 Пример нижней установки окна в многослойной стене.  
 Beispiel des unteren Türanschlagens in einer Schichtenmauer.

**A M B E R L I N E**

Amberline Sp. z o.o.

78-100 Kołobrzeg, ul. K. Kolumba 20

[www.amberline.eu](http://www.amberline.eu)